

Taking Care of Your E2M Series Rotating Disk Electrode

Document LMECE2M

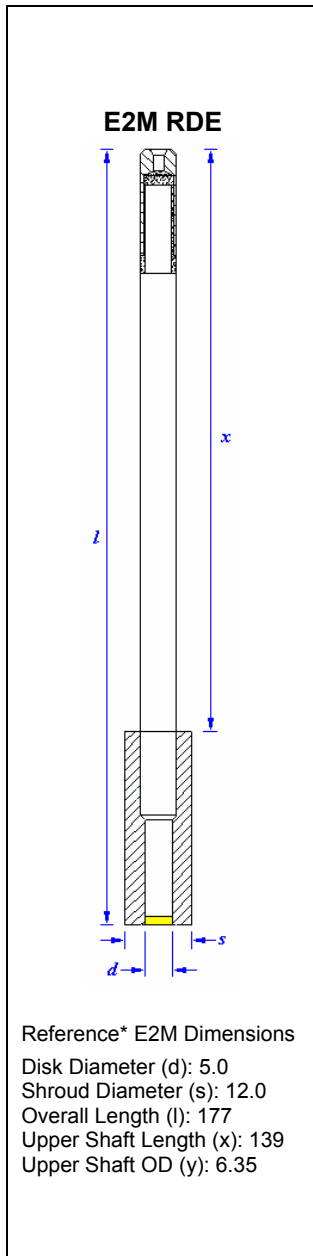

Your rotated disk electrode (RDE) is a precision research tool that has been carefully machined and tested. It is guaranteed to be leak-free at the time of shipment. (Leak test results are attached.)

- Your electrode was leak tested at ambient temperature and should not be used at elevated temperatures. The electrode should only be used at temperatures from 10°C (50°F) to 25°C (77°F). Higher temperatures may create a leak between the shroud and the electrode material.
- After using the electrode, clean it and replace the protective cover to prevent the electrode surface from being scratched.
- Rotating electrodes must be mounted securely in the rotator. While mounting, do not apply excessive force to the Teflon shroud as this may cause the shroud to slip along the shaft of the electrode.
- Rotating electrodes should be submerged at least 5 mm (0.2 in) below the surface of the solution.
- Rotating electrodes should be mounted in such a way that they do not rub against surfaces (such as the inner wall of the cell).

**MAXIMUM ROTATION RATE
7,000 RPM**

**Use Extreme Caution When Rotating
Electrodes over 2000 RPM!**

*Reference dimensions given in millimeters; however, electrodes are actually machined using the nearest English dimensions. Custom electrodes with other dimensions are available upon request.